



BELVEN

Brass Ball Valve

FIG.BBV-600TL

600 WOG FULL PORT FORGED BRASS BALL VALVE THREADED ENDS

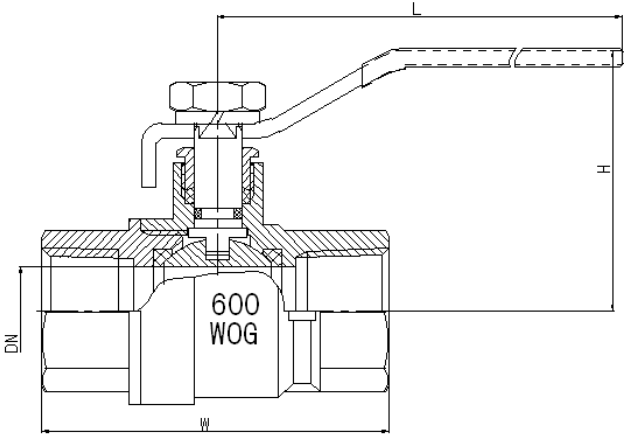

Features:

- Thread Conform ANSI B1.20.1
- Forged Brass Body
- Blow Out Proof Stem Design
- Packing Nut, O-RING & Packing On The Stem Seal
- Brass/Chrome Plated Or Stainless Steel Ball
- Handle With Vinyl Grip

Performance Rating:

- 600 psi (WOG) 150 psi (WSP) Service
- Temperature Range : -20° F to 300° F

Material List:

Part Name	Material
Body	Brass
Seat	PTFE
Ball	Brass/Chrome Plated (1/4" - 1")
	Stainless Steel((1 1/4" - 4")
Stem O-Ring	NBR
Packing Nut	Brass
Stem	Brass (1/4" - 2")
	Stainless Steel(2 1/2" - 4")
Lock Nut	Ferrum /Zinc Plated
Lock Washer	Ferrum /Zinc Plated
Packing	PTFE
Handle	Ferrum /Chrome Plated
Cap	Brass

Approvals:

CSA:	1/4" - 4" Per ANSI Z21.15/CSA 9.1 for 1/2 psig
	1/4" - 4" Per ASME B16.44 /CR91-002 for 5 psig
	1/4" - 2" Per CGA3.16 for 125 psig
	1/2" - 2" Per ASME B16.33 for 125 psig
	2 1/2" - 4" Per ASME B16.38 /CGA3.16 for 125 psig
UL:	1/4" - 4" UL 842 (Guide YRBX,MHKZ)
	1/4" - 4" UL 125 (Guide YSDT,YRPV)
	1/4" - 4" UL 1477 (Guide YQNZ)
FM:	1/4" - 2" Per FM1140 for 600psig

Dimensions:

SIZE	DN	L	H	W	Cv	Wt.(lbs.)
1/4"	0.394	3.46	1.68	1.73	8.23	0.31
3/8"	0.394	3.46	1.68	1.75	8.23	0.30
1/2"	0.591	3.46	1.81	2.24	18.55	0.45
3/4"	0.748	4.29	2.09	2.52	29.76	0.75
1"	0.984	4.29	2.25	2.97	51.55	1.14
1 1/4"	1.259	5.63	2.52	3.44	84.42	1.76
1 1/2"	1.574	5.63	2.74	3.88	131.93	2.41
2"	1.941	5.63	3.03	4.29	200.35	3.38
2 1/2"	2.520	7.76	4.25	5.53	338.43	7.03
3"	2.893	8.19	4.58	6.14	445.44	9.66
4"	3.838	9.25	5.49	7.79	783.88	18.31