

Brass Ball Valve

FIG. BBV-600FT

600 WOG FLANGED x NPT PUMP ISOLATION VALVE

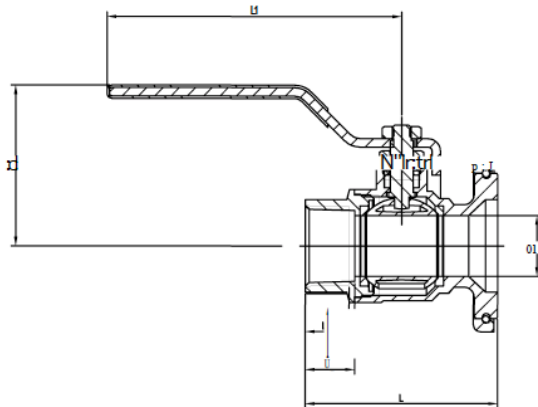
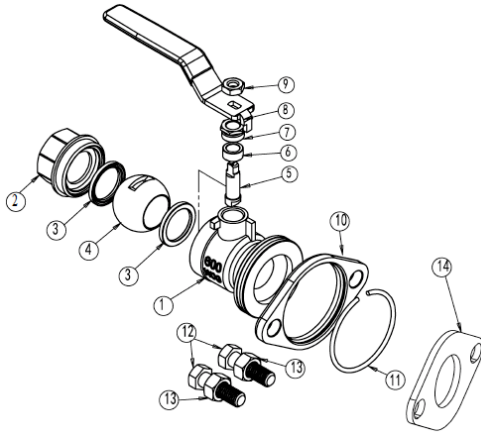

Features:

- Heavy duty forged brass pump isolation valve
- Blow-out proof stem
- Rotating flange (From 3/4" to 1 1/2")
- Adjustable packing gland construction
- 600 WOG rating
- Lever handle
- Threaded end conform to ASME B1.20.1

Material List:

No.	Part Name	Specification
1	Body	Brass
2	Bonnet	Brass
3	Seat Seal	PTFE
4	Ball	Brass
5	Stem	Brass
6	Gasket	PTFE
7	Nut	Brass
8	Handle	Q235
9	Nut	Q235
10	Flange	Brass
11	O-Ring	Stainless Steel
12	Screw	Q235
13	Nut	Q235
14	Rubber Gasket	EPDM

Options:

- Wing handle
- Removable flange

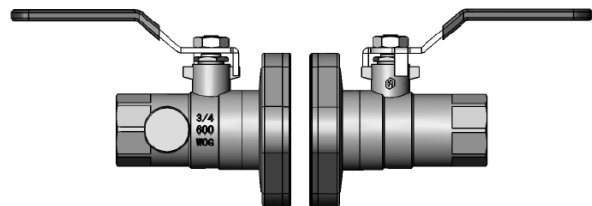

Dimensions: (mm)

Size		Dimension				
in	mm	L	L1	L2	L3	H
3/4"	Ø19	60.8	100	14	16	56.3
1"	Ø25	79.3	123	18	20	68
1 1/4"	Ø31.5	83	123	17.3	19.8	73.8
1 1/2"	Ø38	100.6	152	17.3	20	89.5