



BRONZE GLOBE VALVE

FIG.BZG-125C

CLASS 125 BRONZE GLOBE VALVE SOLDER JOINT ENDS SCREW-IN BONNET NON-RISING STEM SOLID WEDGE

Features:

- Valves comply to: MSS SP-80
- 125PSI/8.6 Bar Saturated Steam to 353° F/ 178° C
- 200 PSI/13.8 Bar Non-Shock Cold Working Pressure

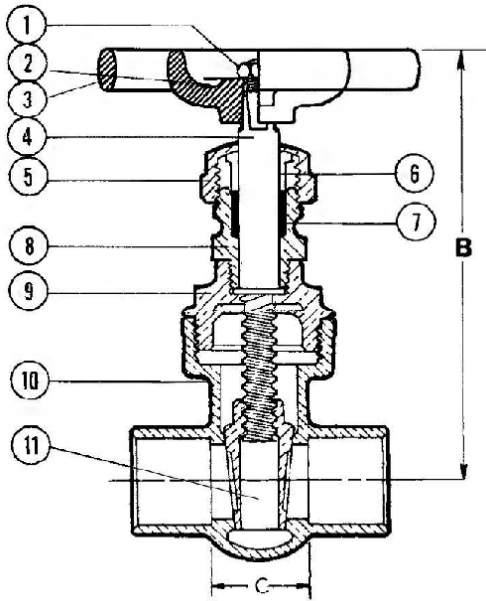

Materials:

No.	Part Name	Specification
1	Handwheel nut	Malleable Iron ASTM A 47
2	Name plate	Aluminum
3	Handwheel	Malleable Iron ASTM A 47
4	Stem	ASTM B99 Alloy C65100
5	Packing nut	Brass ASTM B16 C39600
6	Packing Gland	Brass ASTM B16 C39600
7	Packing	Aramid Fibers with Graphite
8	Stuffing Box	Bronze ASTM B 62
9	Bonnet	Bronze ASTM B 62
10	Body	Bronze ASTM B 62
11	Wedge	Bronze ASTM B 62

Dimension:

Size		A		B		C		Weight	
in	mm	in	mm	in	mm	in	mm	lb	kg
½	15	1.94	49	3.63	92	0.75	19	0.67	0.31
¾	20	2.06	54	3.91	99	0.88	22	0.99	0.45
1	25	2.44	62	4.69	119	1	25	1.6	0.72
1 ¼	32	2.63	67	5.22	133	1.19	32	2.25	1.02
1 ½	40	2.88	72	6.25	159	1.25	33	3.17	1.44
2	50	3.06	78	7.06	179	1.31	34	4.6	2.09
2 ½	65	4.13	105	8.41	224	1.81	46	8.78	3.98
3	80	4.5	114	10	254	1.94	49	12.84	5.82