

3-PIECE STAINLESS STEEL & CARBON STEEL BALL VALVE

FIG.SBV-301TL
FIG.CBV-301TL

1000 WOG 3-PIECE BALL VALVE FULL PORT THREADED ENDS

Features:

- Three-piece design for fast, economical in-line maintenance
- Adjustable packing gland. Bottom-loaded blow-out proof stem.
- Basic design complied with ANSI B16.34 & EN 12516-1.
- NPT threaded ends complied with ANSI B 1.20.1.
- Rc, Rp & G Threaded ends complied with BS 21/2779, JISB-0203/0202, DIN 259/2999, ISO 228-1, AS1722.1/1722.2 are upon request.
- Socket weld ends complied with ANSI B 16.11 are upon request.
- Tested according to API 598.



Materials List:

No.	Part Name	S-301T	C-301T
1	End cap	ASTM A351-CF8M/316	ASTM A216-WCB
2	Ball	ASTM A351-CF8M/316	ASTM A351-CF8/304
3	Seat	PTFE	PTFE
4	Gasket	PTFE	PTFE
5	Body	ASTM A351-CF8M/316	ASTM A216-WCB
6	Thrust washer	PTFE	PTFE
7	Stem packing	PTFE	PTFE
8	Gland	AISI 304	AISI 304
9	Stem	ASTM A276-316	ASTM A276-304
10	Handle washer	AISI 304	AISI 304
11	Handle nut	AISI 304	AISI 304
12	Bolt	AISI 304/GR. B8	Carbon Steel / GR. B7
13	Nut	AISI 304/GR. 8	Carbon Steel / GR. 2H
14	Bolt washer	AISI 304	Carbon Steel
15	Handle	AISI 304	Zinc Plated Steel
16	Handle cover	PVC	PVC

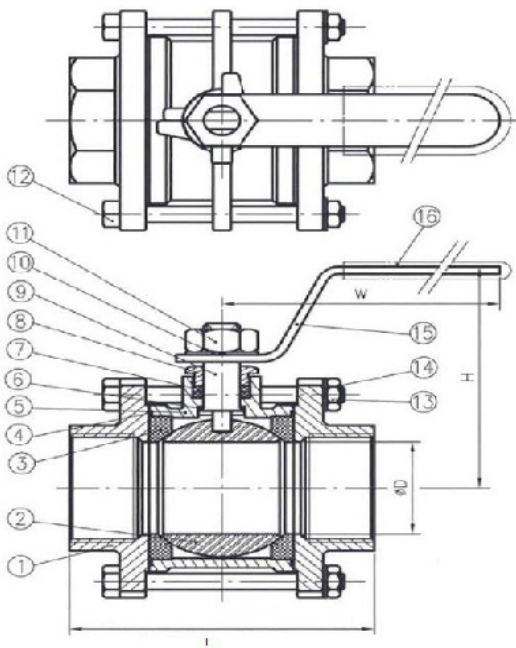

OPTIONS:

- L: LOCKING DEVICE
- V: VENTED BALL

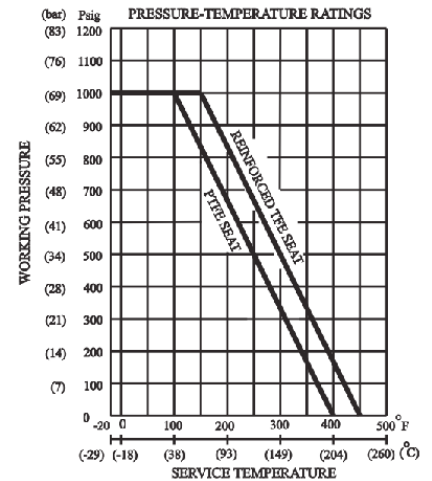
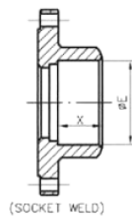

Dimension

Size		Ø D		L		H		Ø E		W		X	
in	mm	in	mm	in	mm	in	mm	in	mm	in	mm	in	mm
¼	8	0.43	11	2.56	65	2.05	52	0.555	14.2	3.7	94	0.39	10
⅜	10	0.49	12.5	2.56	65	2.05	52	0.69	17.6	3.7	94	0.39	10
½	15	0.59	15	2.76	70	2.09	53	0.855	21.8	3.7	94	0.51	13
¾	20	0.79	20	3.15	80	2.22	56.5	1.065	27.2	3.7	94	0.59	15
1	25	1	25.4	3.54	90	2.58	65.5	1.33	33.9	4.37	111	0.59	15
1 ¼	32	1.26	32	4.13	105	2.8	71	1.675	42.7	4.37	111	0.59	15
1 ½	40	1.5	38	4.72	120	3.5	89	1.915	48.8	6.57	167	0.63	16
2	50	1.97	50	5.28	134	3.84	97.5	2.406	61.2	6.57	167	0.67	17
2 ½	65	2.56	65	6.5	165	5.06	128.5	2.906	73.9	9.57	243	0.67	17
3	80	3.15	80	7.28	185	5.47	139	3.535	89.8	9.57	243	0.67	17
4	100	3.94	100	9.09	231	6.59	167.5	4.545	115.2	10.79	274	0.79	20