



BELVEN

3-PIECE FORGED STEEL BALL VALVE

FIG.CBV-306STTLM

**6000 WOG CLASS 2500 THREADED ENDS ¼" TO 1 ½": FULL PORT
2": STANDARD PORT ISO 5211 MOUNTING PAD NACE MR-01-75**

Features:

- Strengthened body construction secures Class 2500/6000 psi working pressure rating.
- Use of body O-ring and body joint gasket double secures NO LEAKAGE.
- Live-loaded packing gland for self-adjustment of stem packing compression.
- Rugged lockable lever handles for safety and long service life.
- Body O-rings are placed ahead of the body cap threads, providing a tight seal and protection of threads from flow media.
- Gland bolts allow for easy packing adjustment without handle removal.
- Pressure equalizing seats & Bottom-loaded blow-out proof stem.
- Vented ball equalizes pressure between the body cavity and the flow stream to prevent seat damage due to thermal cycling.
- Full compliance with ASME/ANSI B16.34 & EN12516-1.
- NPT threaded ends complied with ANSI B1.20.1.
- NPTF threaded ends complied with ANSI B1.20.3.
- Rc, Rp & G Threaded ends complied with BS 21 /2779, JIS B-0203/0202, DIN 259/2999, ISO 228-1, AS 1722.1/1722.2 are upon request.
- Tested according to API 598.

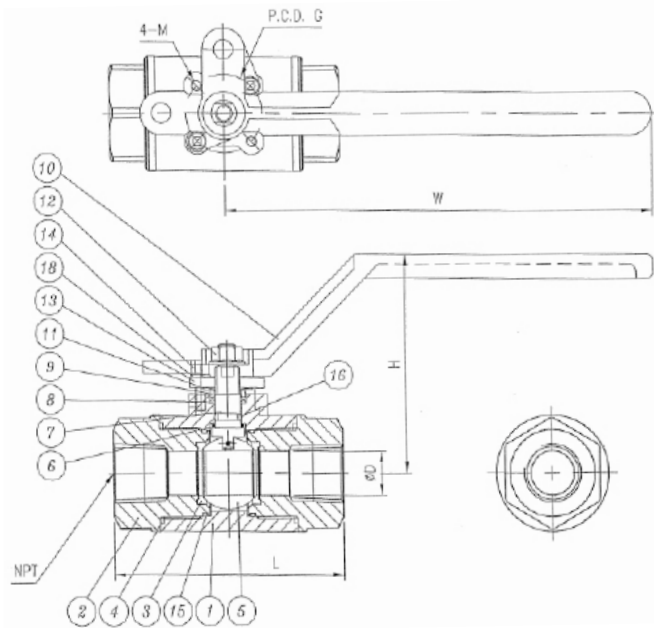

Materials:

No.	Part Name	C-336TT-LCC
1	Body	ASTM A350-LCC
2	End cap	ASTM A350-LCC
3	Seat	PEEK
4	Gasket	Graphite
5	Ball	CF8M/316
6	Thrust Washer	PEEK
7	Stem	ASTM A564-630
8	Stem Packing	Graphite
9	Gland	AISI 304
10	Handle	Carbon Steel
11	Belleville Washer	AISI 301
12	Handle Nut	AISI 304
13	Gland Flange	Carbon Steel
14	Stop Screw	AISI 304
15	Body O-Ring	HSN (HNBR)
16	Stem O-Ring	HSN (HNBR)

Dimension:

Size	Ø D		L		H		W		Ø G		M	
	in	mm	in	mm	in	mm	in	mm	in	mm		
½	15	0.49	12.5	3.74	95	3.15	80	6.3	160	1.42	36	M5
¾	20	0.79	20	4.25	108	3.9	99	7.87	200	1.42	36	M5
1	25	0.98	25	4.72	120	4.09	104	7.87	200	1.42	36	M5
1 ½	25	1.50	38	5.59	142	5.03	127.7	9.84	250	1.97	50	M6
2	25	1.50	38	6.10	155	5.03	127.7	9.84	250	1.97	50	M6

