



3-PIECE FORGED STEEL BALL VALVE

FIG.CBV-306SSLMF 6000 WOG CLASS 2500 EXTENDED SOCKET WELD X SOCKET WELD ENDS ¼ TO 1 ½ FULL PORT 2 STANDARD PORT ISO 5211 MOUNTING PAD NACE MR-01-75

Features:

- Forged steel body construction secures Class 2500/6000 psi working pressure rating.
- LF2 valve body & end caps for low-temperature applications.
- Special design of extended socket weld end facilitates heat dissipation during welding. No prior disassembly of valve is required therefore welding installation process is shortened.
- Use of body O-ring and body joint gasket double secures NO LEAKAGE.
- Live-loaded packing gland for self-adjustment of stem packing compression.
- Rugged lockable lever handles for safety and long service life.
- Body O-rings are placed ahead of the body cap threads, providing a tight seal and protection of threads from flow media.
- Gland bolts allow for easy packing adjustment without handle removal.
- Pressure equalizing seats & Bottom-loaded blow-out proof stem.
- Vented ball equalizes pressure between the body cavity and the flow stream to prevent seat damage due to thermal cycling.
- Full compliance with ASME/ANSI B16.34 & EN12516-1.
- Socket weld ends complied with ANSI B16.11 & EN 12760.
- Tested according to API 598.

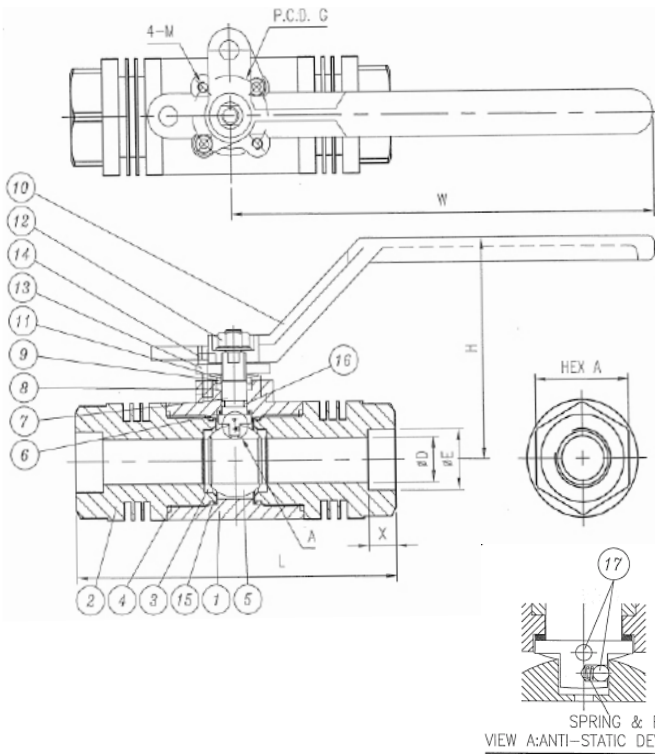

Materials:

No.	Part Name	C-336SS-LF2
1	Body	ASTM A350-LF2
2	End cap	ASTM A350-LF2
3	Seat	PEAK
4	Gasket	Graphite
5	Ball	CF8M/316
6	Thrust Washer	PEEK
7	Stem	ASTM A564-630
8	Stem Packing	Graphite
9	Gland	AISI 304
10	Handle	Carbon Steel
11	Belleville Washer	AISI 301
12	Handle Nut	Carbon Steel
13	Gland Flange	Carbon Steel
14	Gland Bolt	AISI 304
15	Body O-Ring	HSN (HNBR)
16	Stem O-Ring	HSN (HNBR)
17	ANTI-STATIC DEVICE	AISI 316

Dimension:

Size	Ø D		Ø E		L		H		W		X		A		Ø G		M	
	in	mm	in	mm	in	mm	in	mm	in	mm	in	mm	in	mm	in	mm		
½	15	0.49	12.5	0.86	21.8	4.61	117	3.17	80.5	6.3	160	0.39	10	1.50	38	1.42	36	M5
¾	20	0.79	20	1.07	27.2	5.98	152	3.92	99.5	7.87	200	0.51	13	1.73	44	1.42	36	M5
1	25	0.98	25	1.33	33.9	6.46	164	4.09	104	7.87	200	0.51	13	2.09	53	1.42	36	M5
1 ½	40	1.5	38	1.92	48.8	7.87	200	5.07	128.7	9.84	250	0.51	13	2.91	74	1.97	50	M6
2	50	1.5	38	2.41	61.2	8.07	205	5.07	128.7	9.84	250	0.64	16.2	3.62	92	1.97	50	M6

