

Large Diameter Butterfly Valve

FIG.BT-200WL/GO

Large Diameter – Wafer & Full Lug Cast Iron Butterfly Valve



Features:

- Valves meet MSS-SP67 & API 609
- Flange drilling to: ANSI B16.1 Class 125/150
- Testing to: API 598

Test Pressures	Shell: 225 psi
	Seat: 165 psi

Materials List:

No.	Part Name	BW-2000-11DBG BL-2000-11DBG	BW-2000-22DEG BL-2000-22DEG
1	Screw	Carbon Steel	Carbon Steel
2	Bottom Cover	Ductile Iron	Ductile Iron
3	O-ring	Buna-N	Buna-N
4	Lower Bushing	PTFE	PTFE
5	Body	Ductile Iron	Ductile Iron
6	Stem	SS410	SS410
7	Disc	Ductile Iron	CF8M SS316
8	Tap Pin	Carbon Steel	Carbon Steel
9	Seat Cartridge	Buna-N w/Phenolic Backing Ring	EPDM w/Phenolic Backing Ring
10	Mid Bushing	PTFE	PTFE
11	Nameplate	Carbon Steel	Carbon Steel
12	Upper Bushing	PTFE	PTFE
13	O-Ring	Buna-N	Buna-N
14	Key	Carbon Steel	Carbon Steel

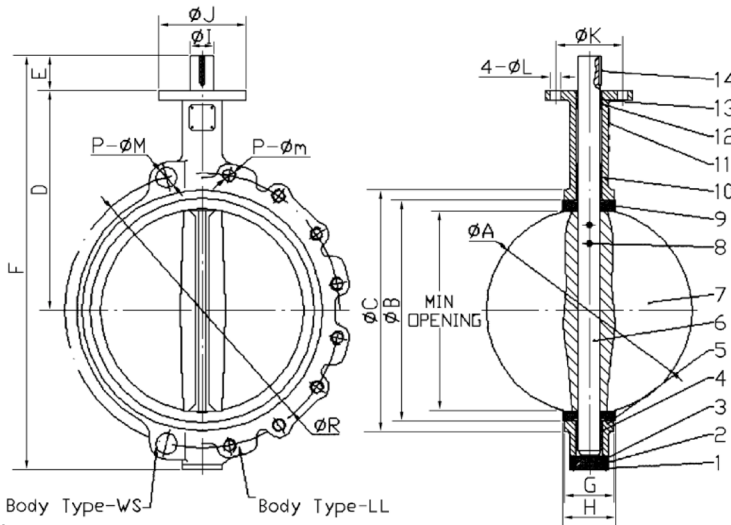

Temperature range of seats

Material	Range
Buna-N	-12°C ~+ 93°C
EPDM	-30°C ~+ 140°C
Neoprene	-7°C ~+ 107°C
Hypalon	-18°C ~+ 149°C
Viton	-12°C ~+ 140°C

Note:
All seats are a cartridge style with the “rubber” bonded to a phenolic backing ring for support.
Seat materials are capable of withstanding lower temperatures without damage. However, the elastomer becomes hard and torques increase.
Some flow media may further restrict the published temperature limits and/or significantly reduce seat life.

- Options:**
- **Disc:** Nickel plated ductile iron, Aluminum bronze, 304SS, 316SS, WCB, Nylon coated DI, PTFE coated DI.
 - **Body:** Cast iron, ductile iron, WCB, 304SS, 316SS, Aluminum bronze.
 - **Seat:** Buna-N, EPDM, Viton, PTFE, Hypalon, Neoprene.
 - **Stem:** 416SS, 431SS, 410SS, 316SS.

Dimensions:

Size	A		Min		B		C		D		E		F		G		H		
in	mm	in	mm	in	mm	in	mm	in	mm	in	mm	in	mm	in	mm	in	mm	in	mm
14	350	13.10	333.30	12.70	322.00	14.80	375.10	15.90	405	14.50	368	1.77	45	26.80	680.00	3.01	76.50	3.13	79.50
16	400	15.30	389.60	14.90	379.10	17.30	439.50	18.50	470	15.70	400	2.83	72	30.70	780.60	3.37	85.70	3.54	90.00
18	450	17.30	440.50	16.80	426.80	19.30	490.50	20.50	521	16.60	422	2.83	72	32.30	821.60	4.12	104.60	4.29	109.00
20	500	19.50	491.60	18.60	472.70	21.10	535.40	22.20	565	18.90	480	3.23	82	36.10	916.00	5.13	130.30	5.31	135.00
24	600	23.30	592.50	22.50	571.60	25.70	654.00	27.30	693	22.10	562	3.23	82	43.40	1102.70	5.96	151.40	6.14	156.00
30	750	27.70	703.60	28.20	716.30	31.10	789.90	34.10	866	25.50	648	2.60	66	51.80	1315.70	6.59	167.40	6.77	172.00

Size	ØI		ØJ		ØK		ØL		P	P-m	P-M	R	Weight LL		Weight WS				
in	mm	in	mm	in	mm	in	mm	in	mm	in	mm	in	mm	lb	kg	lb	kg		
14	350	1.24	31.60	5.51	140	4.02	102	4-.47	12	0.63	16	1	1 1/8	18.10	460	123	56.00	91	41.30
16	400	1.50	38.00	7.76	197	5.51	140	4-.71	18	0.63	16	1	1 1/8	20.30	515	215	97.70	139	63.00
18	450	1.69	42.90	7.76	197	5.51	140	4-.71	18	0.79	20	1 1/8	1 1/4	22.20	565	272	123.80	178	80.70
20	500	1.80	45.70	7.76	197	5.51	140	4-.71	18	0.79	20	1 1/8	1 1/4	24.40	620	448	203.70	286	129.80
24	600	2.13	54.00	10.87	276	6.50	165	4-.87	22	0.79	20	1 1/4	1 3/8	28.50	725	602	273.50	422	191.60
30	750			11.81	300	10.00	254	8-.71	18	0.79	20	1 1/4	1 3/8	36.00	914	814	370.00	760	345.50