



BELVEN

CAST STEEL CHECK VALVE

FIG. CSCV-300F:

CLASS 300 SWING CHECK VALVE FLANGED ENDS BOLTED COVER WCB BODY & BONNET 13Cr/HF TRIM



Features:

- Flange dimensions: ANSI B16.5
- Face-to-Face dimensions: ANSI B16.10
- Testing: API 598
- Design: API 600

Materials List:

No.	Part Name	Specification
1	Body	A216 WCB
2	Cover	A216 WCB
3	Disc	A216 WCB + 13Cr overlay
4	Hinge	A216 WCB
5	Hinge Pin	A276 – 410
6	Name Plate	304SS
7	Set Screw	A276 – 410
8	Hook Screw	Carbon steel
9	Disc Nut	A276 – 410
10	Gasket	304 Wound Grafoil
11	Stud/nut	B7/2H
12	Seat Ring	A105 + HF

Note:

- Standard valve has a welded seat ring
- Other body materials and trims are available upon request

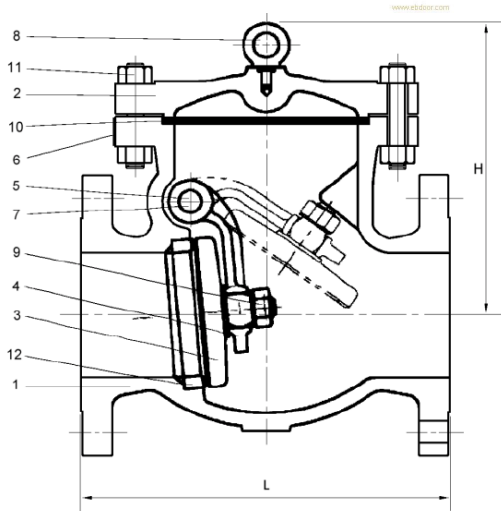

Dimensions:

Size		L		H		Weight	
in	mm	in	mm	in	mm	lb	kg
2	50	10 ½	267	7	180	66	30
2 ½	65	11 ½	292	7 ¼	185	90	41
3	80	12 ½	318	8 ¼	210	110	50
4	100	14	356	10 ⅝	270	161	73
5	125	15 ¾	400	13 ½	345	200	91
6	150	17 ½	444	14 ¼	360	330	150
8	200	21	533	14 ½	370	510	232
10	250	24 ½	622	15 ⅝	385	774	352
12	300	28	711	17 ¼	440	1151	523
14	350	33	838	20 ½	520	1500	682
16	400	34	864	21 ¾	554	1850	841
18	450	38 ½	978	23 ¼	590	2255	1025
20	500	40	1016	24 ¼	614	2904	1320
24	600	53	1346	28	710	4314	1961
30	750	62 ¾	1594	34	865	7194	3270