

# Grooved Butterfly Valve with Tamper Switch

Fig. No. XD381X

003073.7



XD381X

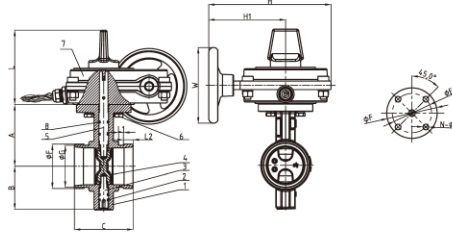

- Design Standard: MSS SP-67
- Connection Ends: Groove to AWWA C606
- Top Flange Standard: ISO 5211
- Working Pressure: 300PSI/363PSI  
175PSI, 200PSI and 250PSI available upon request
- Temperature Range: 0°C - 80°C
- Coating: Fusion Bonded Epoxy Coating in accordance with ANSI/AWWA C550

MATERIAL SPECIFICATION

Part No.	Part	Standard Specification	Options
1	Body	ASTM A536,65-45-12	
2	O-Ring	NBR	EPDM
3	Stub Shaft	AISI 431	
4	Disc	ASTM A536,65-45-12+EPDM	ASTM A536,65-45-12+NBR
5	Drive Shaft	AISI 431	
6	Hex Nut	Carbon Steel Zinc plated	
7	Signal Gearbox	Body ASTM A536,65-45-12	
8	O-Ring	NBR	EPDM

Note: For special material request other than standard specification, please indicate clearly on the inquiry or order list.

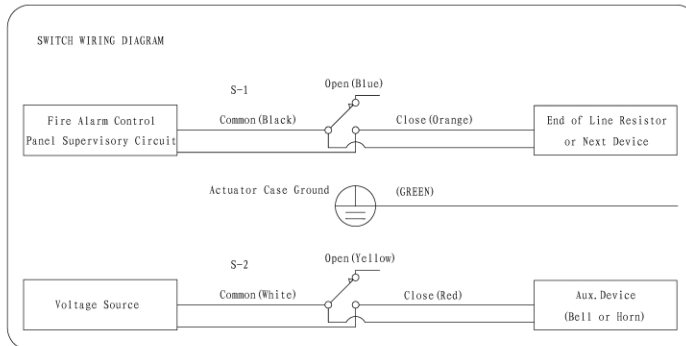

DN		Dimensions(mm)														
Inch	mm	A	B	C	F	G	L	L1	L2	H1	H	W	ΦE	ΦF	N-ΦM	ISO5211
2"	50	89	65	81	60.3	57.15	122.5	7.93	15.88	127	202.2	125	70	90	4-Φ10	F07
2.5"	65	102	71	97	73.0	69.09	122.5	7.93	15.88	127	202.2	125	70	90	4-Φ10	F07
3"	80	109	81	97	88.9	84.94	122.5	7.93	15.88	127	202.2	125	70	90	4-Φ10	F07
4"	100	128	95	116	114.3	110.08	122.5	9.53	15.88	127	202.2	125	70	90	4-Φ10	F07
5"	125	141	111	148	141.3	137.03	122.5	9.53	15.88	127	202.2	125	70	90	4-Φ10	F07
6"	150	153	133	148	168.3	163.96	122.5	9.53	15.88	139.5	215	225	70	90	4-Φ10	F07
8"	200	184	164	133	219.1	214.40	122.5	11.10	19.05	198.5	274	225	102	125	4-Φ12	F10
10"	250	216	196	159	273.1	268.28	122.5	12.70	19.05	198.5	274	225	102	125	4-Φ12	F10
12"	300	254	226	165	323.9	318.29	132.0	12.70	19.05	198.5	293.5	225	102	125	4-Φ12	F10

Note: Valve must not be installed with disc in full open position. Disc must be partly closed so that no part is protruding beyond end of valve body.